

PYROELECTRIC IR SENSOR THERMOPILE SENSOR

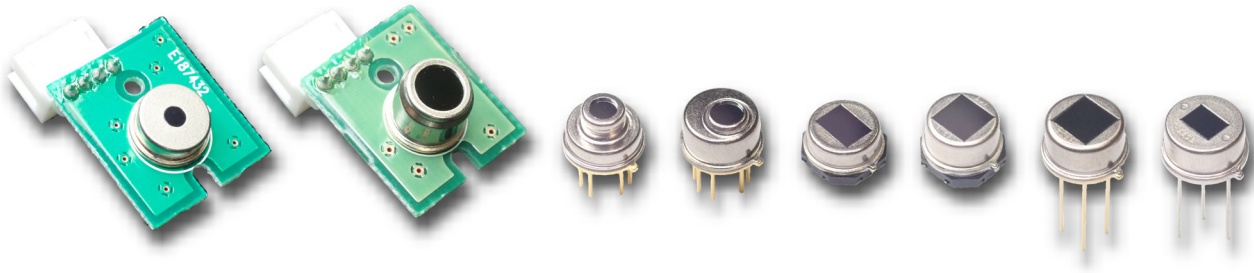

We Make Good World with Sensor



Application Guide

Pyroelectric IR sensor

The pyroelectric infrared sensor is an infrared sensor that applies the pyroelectric effect of ferroelectric ceramic. It can detect human body movement and so on with sensing temperature changes.



Lighting

Automatic switch control.
Energy saving, Comfort & Convenience.



Security

Security & Safety.



Air-conditioner

Comfort & Energy saving.



**IP camera
IoT**

Camera control. Energy saving & battery life extension. Security, Surveillance & Pet monitor.



Toilet

Automatic toilet lid open and close. Comfort, Convenience & Cleanliness.



TV

Automatic display control.
Energy saving & comfort.

Thermopile sensor Thermopile sensor unit

Thermopile sensor is an infrared sensor that applies the Seebeck effect. With detecting absolute thermal amount of the object, it measures temperature without contact.



Printer

Temperature monitor of inside parts. Printing quality and efficiency improvement.



Automotive

Temperature measurement of seat space, passenger, heat generation parts and etc..
Comfort and safety improvement.



Microwave oven

Food temperature measurement. Heat control to preset temperature.



Air-conditioner

Temperature monitor of floor and human body. Comfortability control & energy saving control.



IH cooker

Temperature monitor of pot bottom. Automatic control of cooking temperature.



Ear thermometer

Quick measure of body temperature.

Pyroelectric IR sensors

傳統型,需另加OP及比較器

	Applications						Object (Target tempera ture)	Part number	Number of element	FOV [°]		Shape	Output method	Feature	Data Sheet	
	Lighting	Doorbell	IP Camera	HVAC	Home appliances	Security				Gas/ Flame Detection	X-axis					Y-axis
	<input type="radio"/>	<input type="radio"/>	<input type="radio"/>				Human body, other	RE200G	2	138	125	TO-5 detector	analog	* General Purpose * High PSRR	5	
1	<input type="radio"/>	<input type="radio"/>	<input type="radio"/>				Human body, other	RE200GE	2	138	125	TO-5 detector	analog	* General Purpose * Low voltage operation	6	
2	<input type="radio"/>	<input type="radio"/>	<input type="radio"/>	<input type="radio"/>	<input type="radio"/>		Human body, other	RE200GE-WW	2	145	136	TO-5 detector	analog	* Wide-angle detection dual sensor * Low voltage operation	7	
					<input type="radio"/>		Human body, other	SCG321-611	2	134	120	TO-5 detector	analog	* High EMC	8	
					<input type="radio"/>		Human body, other	SFG223-611	2	145	136	TO-5 detector	analog	* High EMC	9	
3					<input type="radio"/>		Human body, other	SFG323-611	2	134	120	TO-5 detector	analog	* High EMC * High white light immunity	10	
4					<input type="radio"/>		Human body, other	SFG469-711	2	132	146	TO-5 detector	analog	* Omni-directional dual sensor (both ceiling mount and wall mount) 69-Pyro * High EMC	11	
	<input type="radio"/>	<input type="radio"/>	<input type="radio"/>	<input type="radio"/>	<input type="radio"/>		Human body, other	SEG446-711	4	132	146	TO-5 detector	analog	* Omni-directional 4-element and 1-channel sensor (for ceiling mount)	12	
	<input type="radio"/>	<input type="radio"/>	<input type="radio"/>	<input type="radio"/>	<input type="radio"/>		Human body, other	SDG413-611	4	132	132	TO-5 detector	analog	* General Purpose 4-element and 2-channel sensor * Pet immunity sensor	13	
	<input type="radio"/>	<input type="radio"/>	<input type="radio"/>	<input type="radio"/>	<input type="radio"/>		Human body, other	SQG413-612	4	145	145	TO-5 detector	analog	* 4-element and 2-channel sensor * Pet immunity sensor	14	
	<input type="radio"/>	<input type="radio"/>	<input type="radio"/>	<input type="radio"/>	<input type="radio"/>		Human body, other	SLG323-611	2	150	139	TO-5 detector	analog	* Low profile sensor * Low voltage operation	15	
						<input type="radio"/>	Gas, flame	SAAC10-11-G	1	115	115	TO-5 detector	analog	* Single element sensor * Low voltage operation	16	
					<input type="radio"/>		Human body, other	SFM323-511	2	134	120	SMD	analog	* Surface mount type * High EMC * High white light immunity	S-Pyro 17	
9					<input type="radio"/>		Human body, other	SFM469-511	2	132	146	SMD	analog	* Omni-directional dual sensor (both ceiling mount and wall mount) S-Pyro * Surface mount type * High EMC 69-Pyro	18	
	<input type="radio"/>	<input type="radio"/>	<input type="radio"/>	<input type="radio"/>	<input type="radio"/>		Human body, other	SLM323-511	2	152	142	SMD	analog	* Low profile sensor * Surface mount type * High EMC	S-Pyro 20	
#	<input type="radio"/>	<input type="radio"/>	<input type="radio"/>	<input type="radio"/>	<input type="radio"/>		Human body, other	SLM469-511	2	150	159	SMD	analog	* Low profile sensor * Surface mount type S-Pyro * Omni-directional dual sensor 69-Pyro	21	
	<input type="radio"/>	<input type="radio"/>	<input type="radio"/>	<input type="radio"/>	<input type="radio"/>		Human body, other	SUM469-20	2	132	146	SMD	analog	* Omni-directional dual sensor (both ceiling mount and wall mounting) S-Pyro 69-Pyro	22	

Pyroelectric IR sensor



RE200G

■ Applications Lighting, Doorbell, IP Camera

■ Feature General Purpose
High PSRR

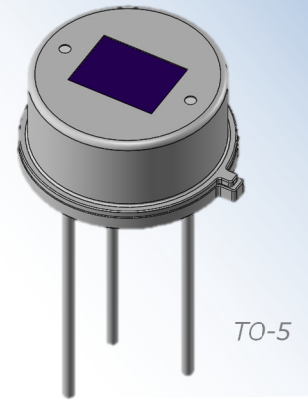

Dimensions

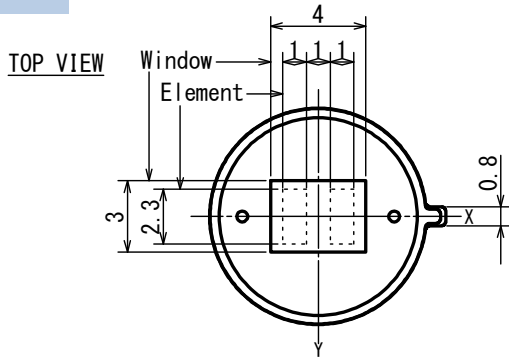

FOV

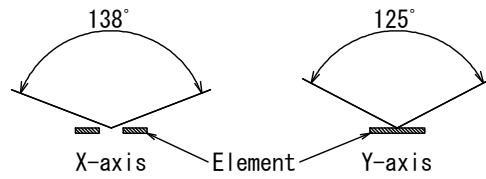

SIDE VIEW

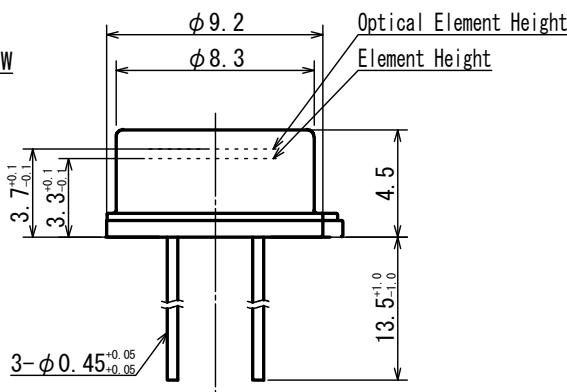

Circuit diagram

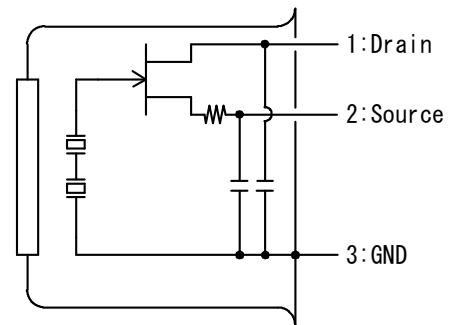

BOTTOM VIEW

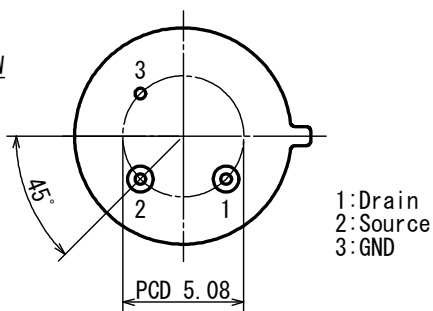

Tolerance with no specified : +/- 0.2

■ Main Parameter

Parameter	Condition	Spec.			Unit
		Min.	Typ.	Max.	
Operating Voltage		3		10	V
Source Voltage	Vd=5V, Rs=47kΩ, Ta=25°C	0.3		1.4	V
Sensitivity Output	72.5dB, 1Hz, 420K	2.1	3.3		V
Noise Output	72.5dB		70	250	mV
Operating Temperature		-20		70	°C

Pyroelectric IR sensor



RE200GE

■ Applications Lighting, Doorbell, IP Camera

■ Feature General Purpose
Low voltage operation

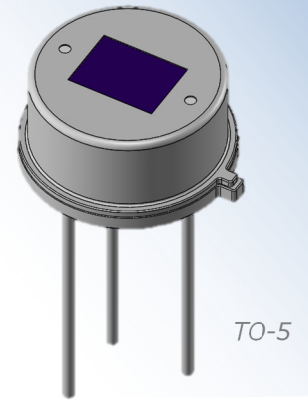

Dimensions

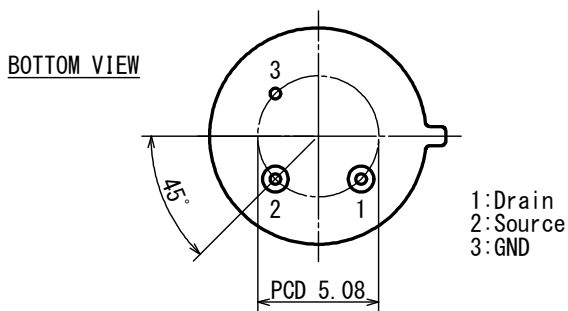
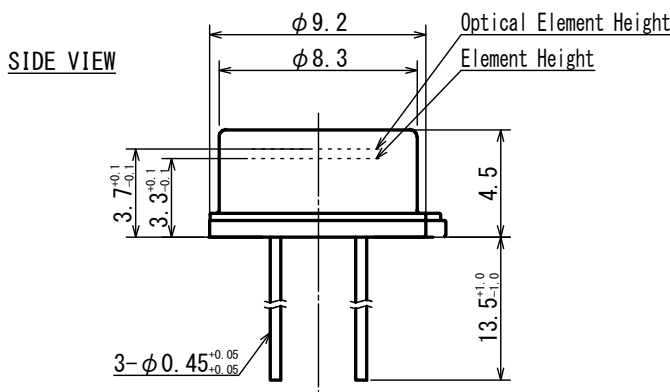
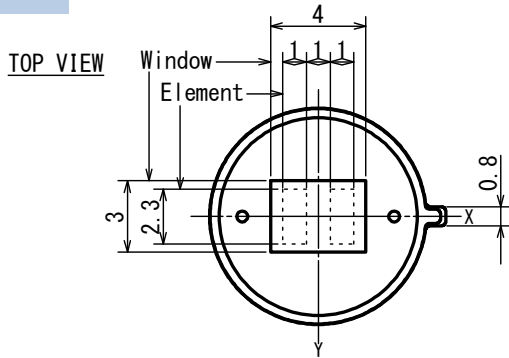

Tolerance with no specified : +/- 0.2

FOV

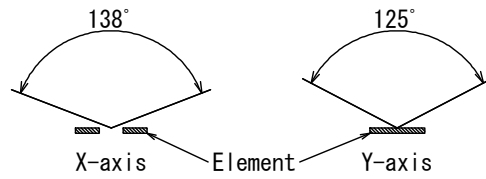

Circuit diagram

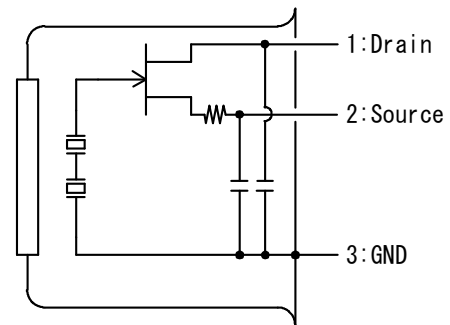

■ Main Parameter

Parameter	Condition	Spec.			Unit
		Min.	Typ.	Max.	
Operating Voltage		1		15	V
Source Voltage	Vd=5V, Rs=470kΩ, Ta=25°C	0.3		1.4	V
Sensitivity Output	72.5dB, 1Hz, 420K	2.5	4		V
Noise Output	72.5dB		90	250	mV
Operating Temperature		-20		70	°C

Analog

Amp build-in
ASIC build-in

SMD

Air-conditioner

Microwave
oven

IH cooker

Printer

Ear
thermometer

Non-contact
thermometer

Pyroelectric IR sensor



RE200GE-WW

■ Applications Lighting, Doorbell, IP Camera
HVAC, Home appliances

■ Feature Wide-angle detection dual sensor
Low voltage operation

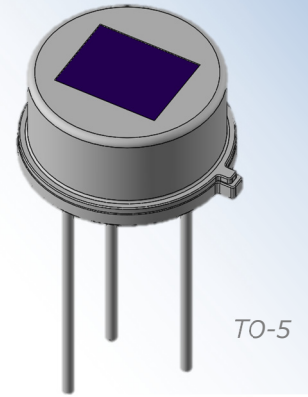

Dimensions

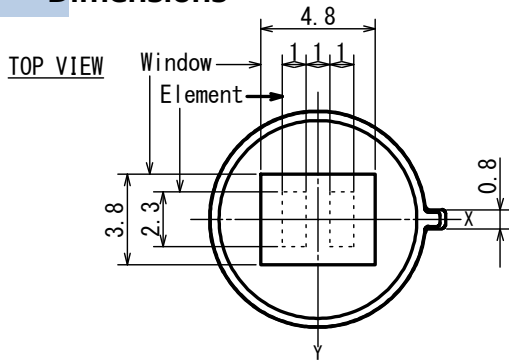

FOV

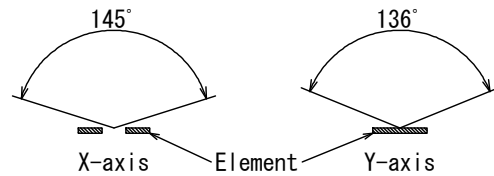

SIDE VIEW

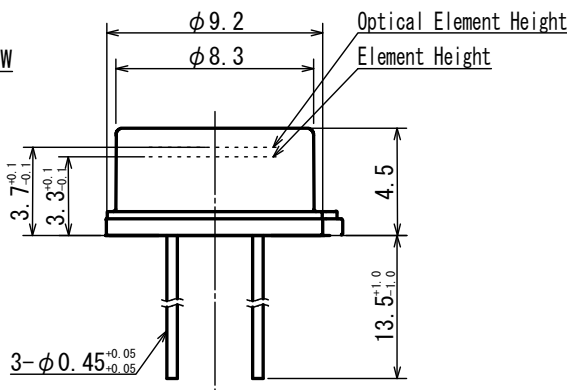

Circuit diagram

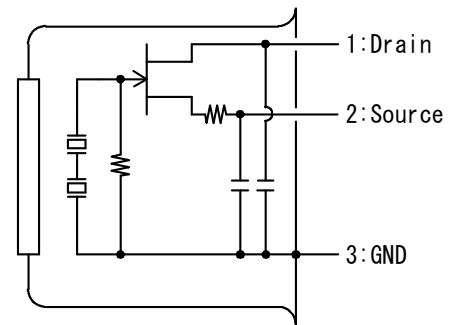

BOTTOM VIEW

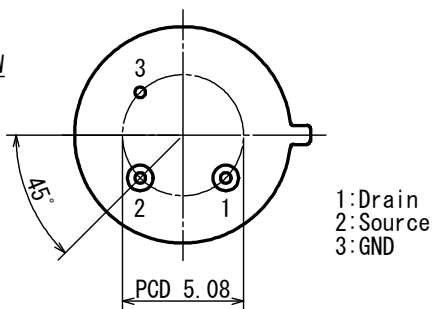

Tolerance with no specified : +/- 0.2

■ Main Parameter

Parameter	Condition	Spec.			Unit
		Min.	Typ.	Max.	
Operating Voltage		1		15	V
Source Voltage	Vd=5V, Rs=470kΩ, Ta=25°C	0.3		1.4	V
Sensitivity Output	72.5dB, 1Hz, 420K	2.5	4		V
Noise Output	72.5dB		90	250	mV
Operating Temperature		-40		70	°C

Pyroelectric IR sensor



SFG223-611

■ Applications Security

■ Feature High EMC

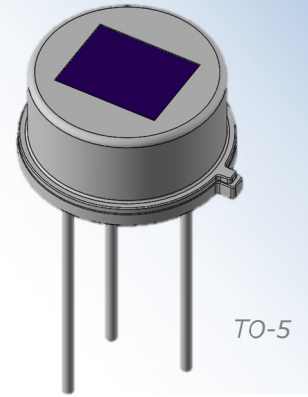

Dimensions

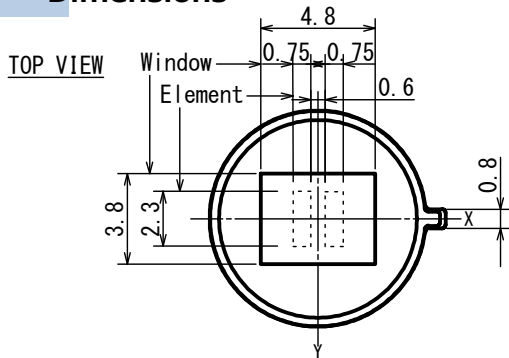

FOV

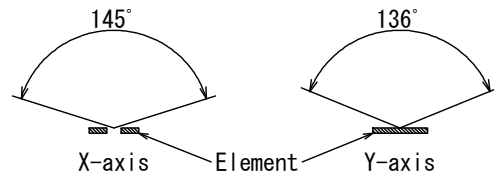

SIDE VIEW

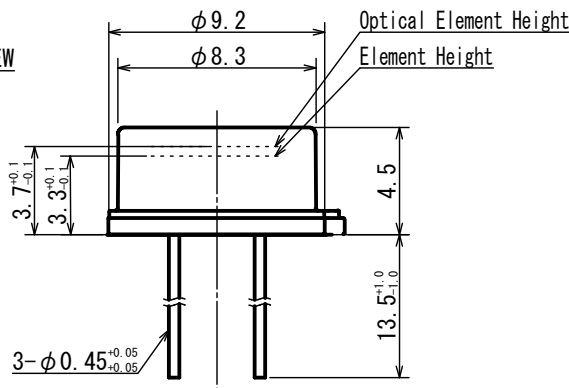

Circuit diagram

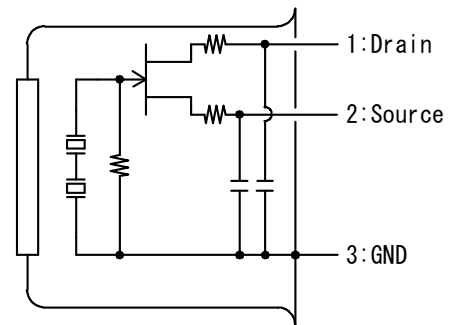

BOTTOM VIEW

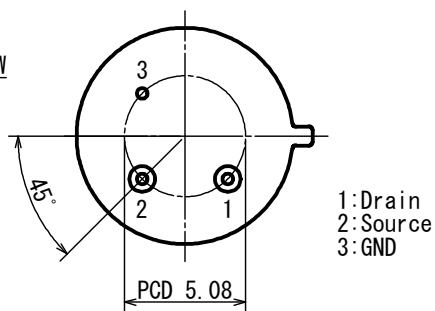

Tolerance with no specified : +/- 0.2

■ Main Parameter

Parameter	Condition	Spec.			Unit
		Min.	Typ.	Max.	
Operating Voltage		1		15	V
Source Voltage	Vd=5V, Rs=470kΩ, Ta=25°C	0.3		1.4	V
Sensitivity Output	72.5dB, 1Hz, 420K	2.5	3.5		V
Noise Output	72.5dB		90	250	mV
Operating Temperature		-50		70	°C

Analog

Amp build-in
ASIC build-in

SMD

Air-conditioner

Microwave
oven

Ih cooker

Printer

thermometer
Ear

Non-contact
thermometer

Pyroelectric IR sensor



SCG321-611

■ Applications Security

■ Feature High EMC

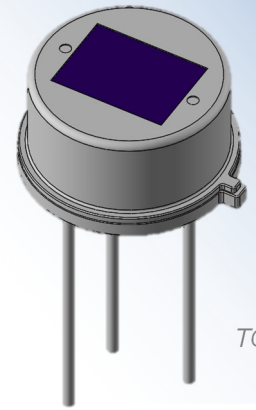

Dimensions

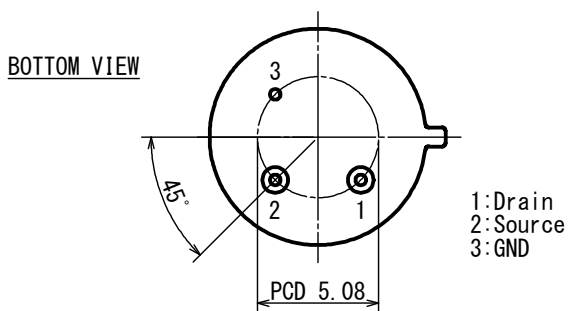
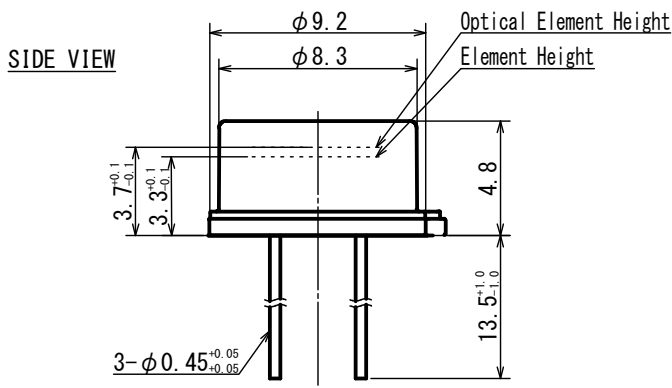
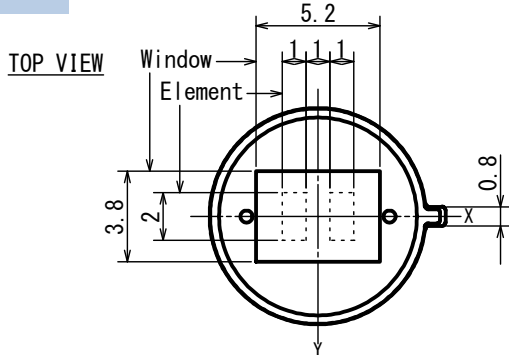

Tolerance with no specified : +/- 0.2

FOV

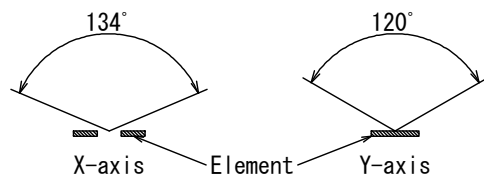

Circuit diagram

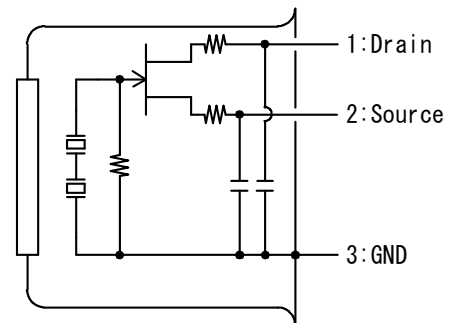

■ Main Parameter

Parameter	Condition	Spec.			Unit
		Min.	Typ.	Max.	
Operating Voltage		1		15	V
Source Voltage	Vd=5V, Rs=470kΩ, Ta=25°C	0.3		1.4	V
Sensitivity Output	72.5dB, 1Hz, 420K	3	4.5		V
Noise Output	72.5dB		90	250	mV
Operating Temperature		-40		70	°C

Analog

Amp build-in
ASIC build-in

SMD

Air-conditioner

Microwave
oven

Ih cooker

Printer

thermometer
Ear

Non-contact
thermometer

Pyroelectric IR sensor



SFG469-711

69-Pyro™

■ Applications Security

■ Feature Omni-directional dual sensor
(both ceiling mount and wall mount)
High EMC

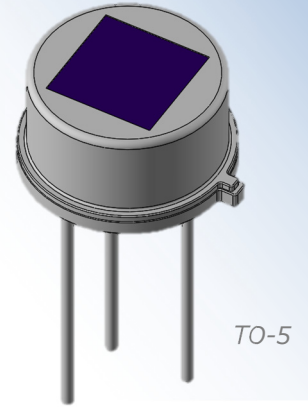

Dimensions

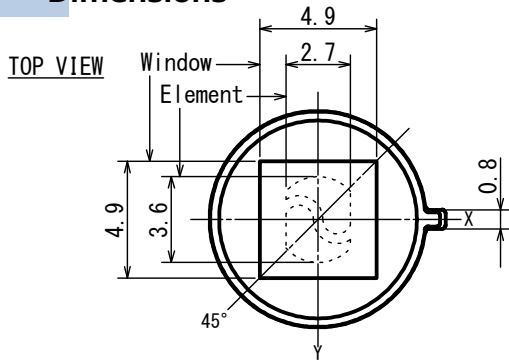

FOV

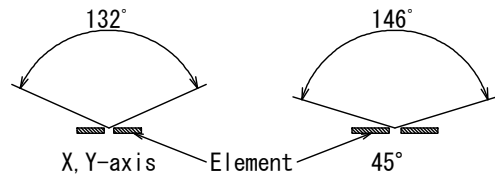

SIDE VIEW

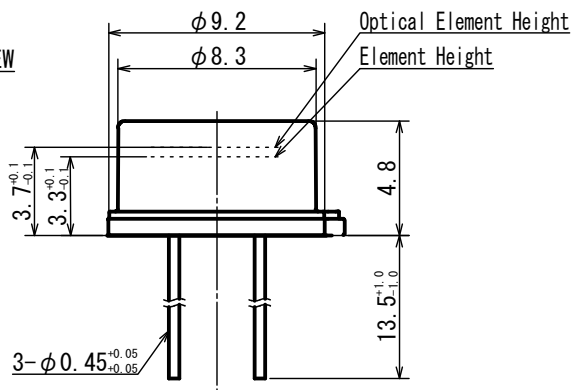

Circuit diagram

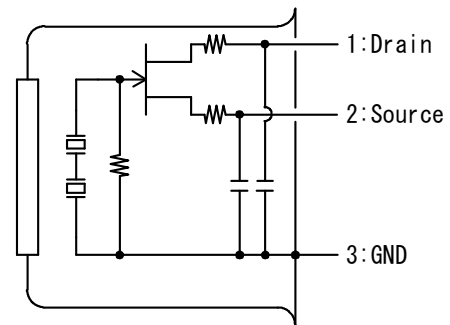

BOTTOM VIEW

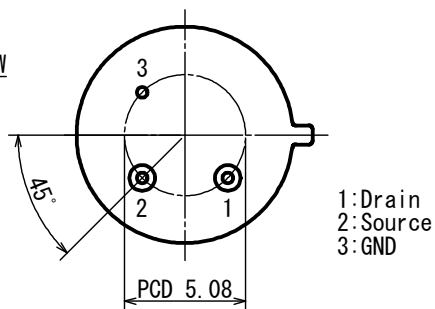

Tolerance with no specified : +/- 0.2

■ Main Parameter

Parameter	Condition	Spec.			Unit
		Min.	Typ.	Max.	
Operating Voltage		1		15	V
Source Voltage	Vd=5V, Rs=470kΩ, Ta=25°C	0.3		1.4	V
Sensitivity Output	72.5dB, 1Hz, 420K	3	5		V
Noise Output	72.5dB		60	200	mV
Operating Temperature		-40		85	°C

Pyroelectric IR sensor



SBG469-711

69-Pyro™

- Applications Lighting, Doorbell, IP Camera
HVAC, Home appliances

- Feature Omni-directional dual sensor
(both ceiling mount and wall mount)

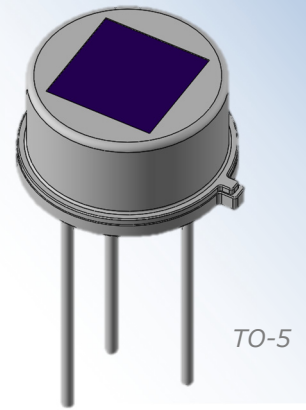

Dimensions

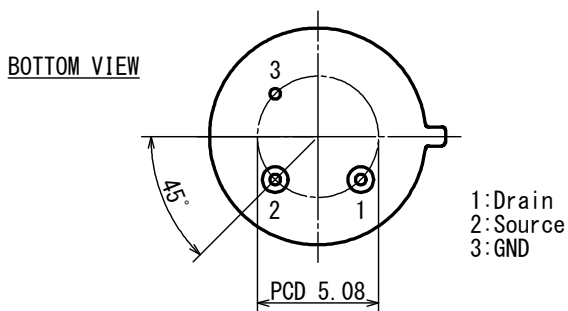
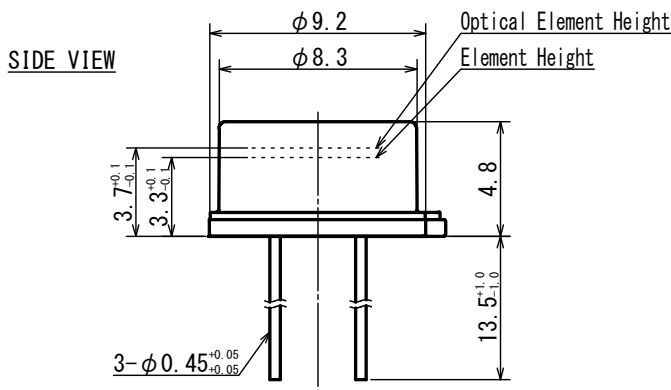
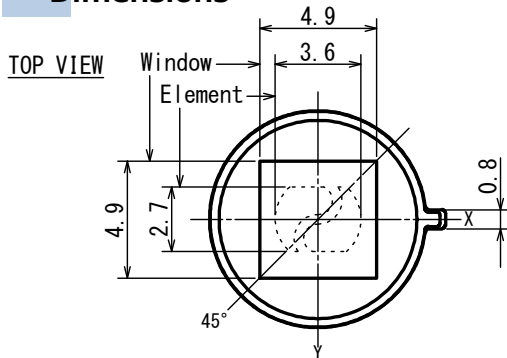

Tolerance with no specified : +/- 0.2

FOV

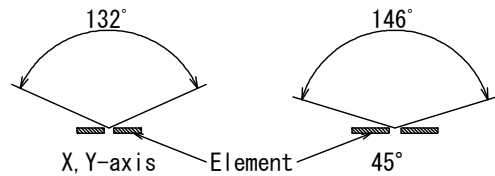

Circuit diagram

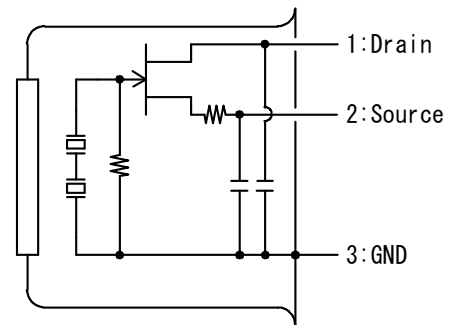

■ Main Parameter

Parameter	Condition	Spec.			Unit
		Min.	Typ.	Max.	
Operating Voltage		1		15	V
Source Voltage	Vd=5V, Rs=470kΩ, Ta=25°C	0.3		1.4	V
Sensitivity Output	72.5dB, 1Hz, 420K	3	5		V
Noise Output	72.5dB		60	200	mV
Operating Temperature		-40		70	°C

Analog

Amp build-in
ASIC build-in

SMD

Air-conditioner

Microwave
oven

Ih cooker

Printer

thermometer
Ear

Non-contact
thermometer

Pyroelectric IR sensor



SEG446-711

- Applications Lighting, Doorbell, IP Camera
HVAC, Home appliances

- Feature Omni-directional 4-element and
1-channel sensor (for ceiling mount)

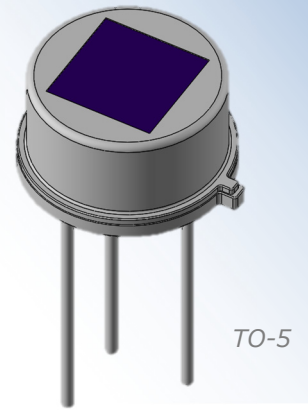

Dimensions

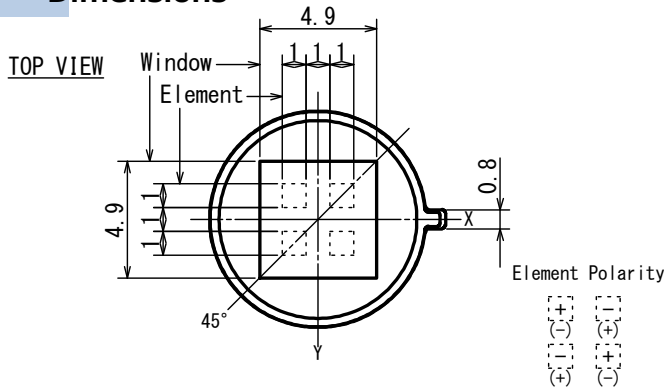

FOV

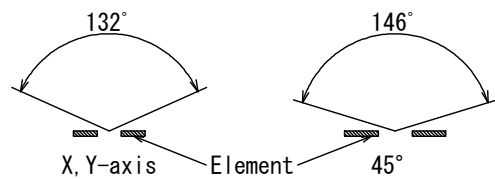

SIDE VIEW

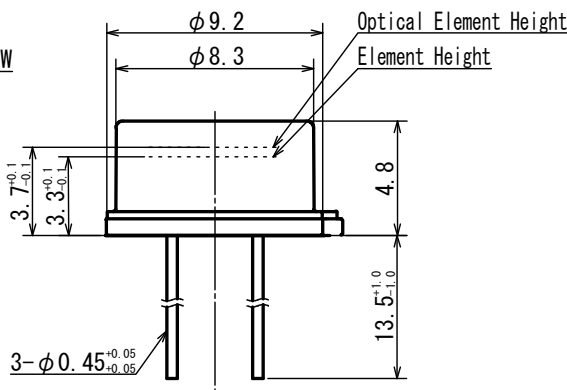

Circuit diagram

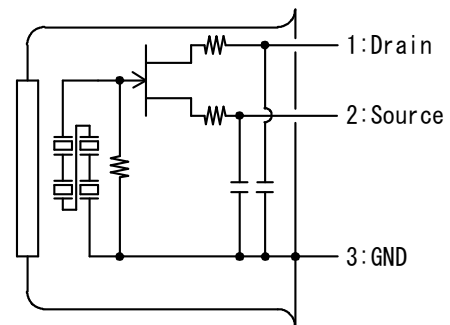

BOTTOM VIEW

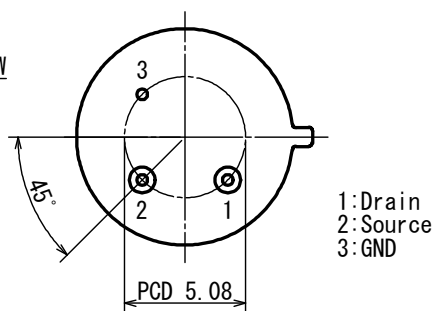

Tolerance with no specified : +/- 0.2

■ Main Parameter

Parameter	Condition	Spec.			Unit
		Min.	Typ.	Max.	
Operating Voltage		1		15	V
Source Voltage	Vd=5V, Rs=470kΩ, Ta=25°C	0.3		1.4	V
Sensitivity Output	72.5dB, 1Hz, 420K	5.3	7		V
Noise Output	72.5dB		150	300	mV
Operating Temperature		-40		70	°C

Pyroelectric IR sensor

SQG413-612

■ Applications Security

■ Feature 4-element and 2-channel sensor
Pet immunity sensor

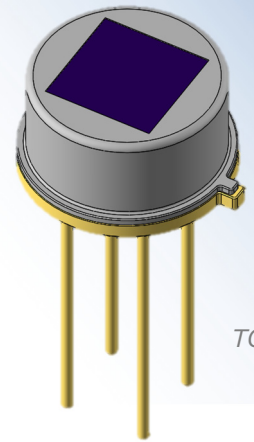

TO-5

Dimensions

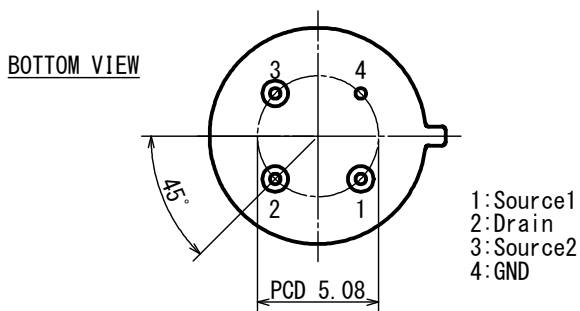
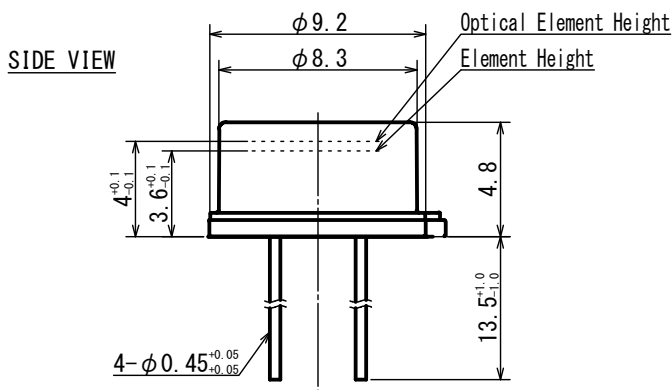
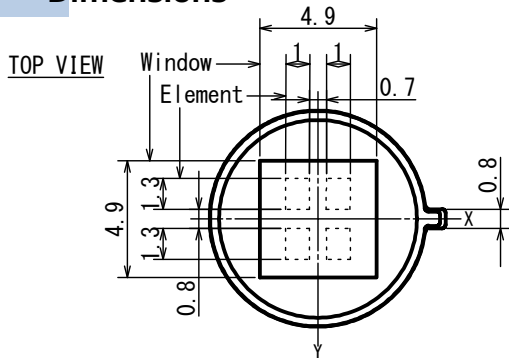

Tolerance with no specified : +/- 0.2

FOV

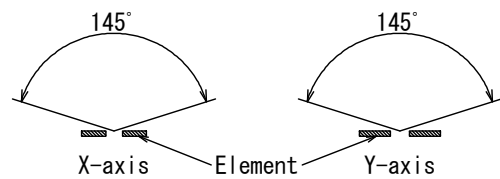

Circuit diagram

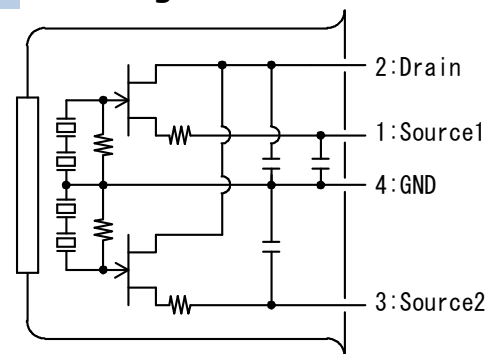

■ Main Parameter

Parameter	Condition	Spec.			Unit
		Min.	Typ.	Max.	
Operating Voltage		1		15	V
Source Voltage	Vd=5V, Rs=470kΩ, Ta=25°C	0.3		1.4	V
Sensitivity Output	72.5dB, 1Hz, 420K	2.5	4.2		V
Noise Output	72.5dB		120	250	mV
Operating Temperature		-40		70	°C

Analog

Amp build-in
ASIC build-in

SMD

Air-conditioner

Microwave
oven

Ih cooker

Printer

Ear
thermometer

Non-contact
thermometer

Pyroelectric IR sensor

SLG323-611

■ Applications Lighting, Doorbell, IP Camera
HVAC, Home appliances

■ Feature Low profile sensor
Low voltage operation

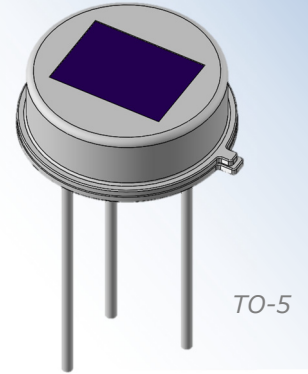

Dimensions

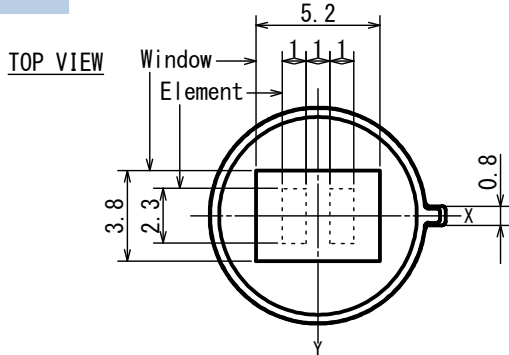

FOV

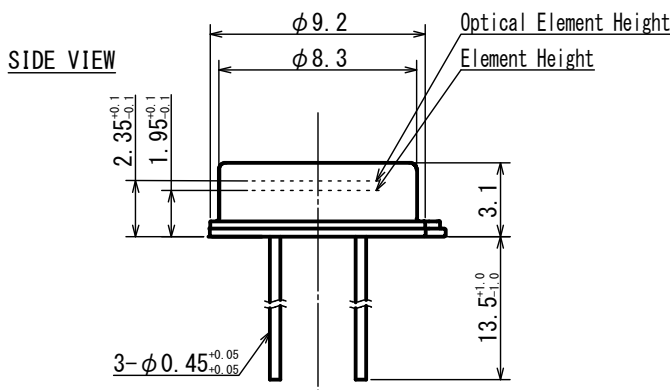
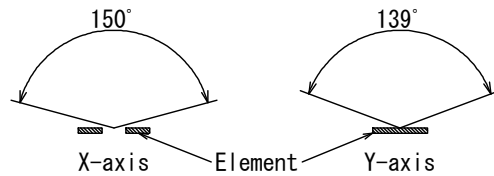

Circuit diagram

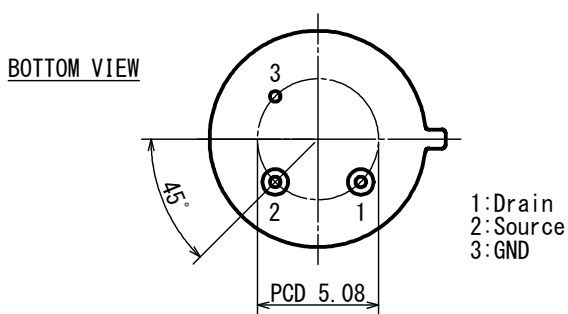
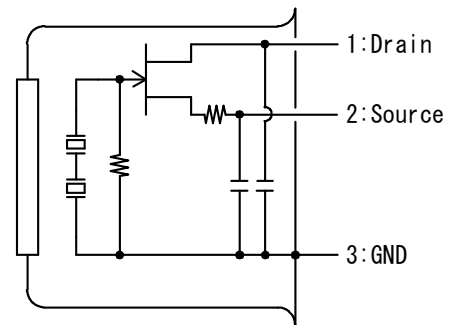

Tolerance with no specified : +/- 0.2

■ Main Parameter

Parameter	Condition	Spec.			Unit
		Min.	Typ.	Max.	
Operating Voltage		1		15	V
Source Voltage	Vd=5V, Rs=470kΩ, Ta=25°C	0.3		1.4	V
Sensitivity Output	72.5dB, 1Hz, 420K	3	4.2		V
Noise Output	72.5dB		90	250	mV
Operating Temperature		-40		70	°C

Pyroelectric IR sensor



SAAC10-11-G

■ Applications Gas/Flame Detection

■ Feature Single element sensor
Low voltage operation

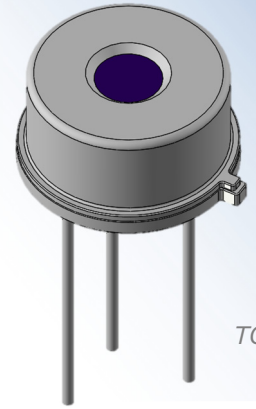

Dimensions

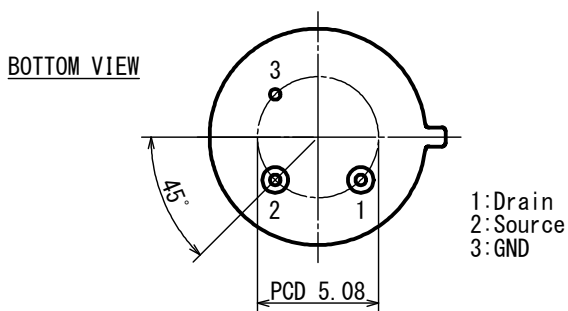
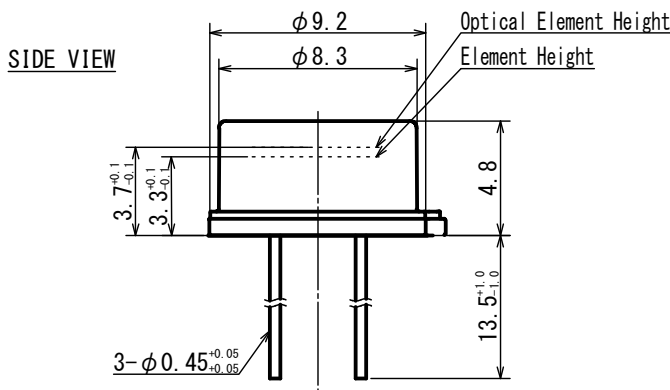
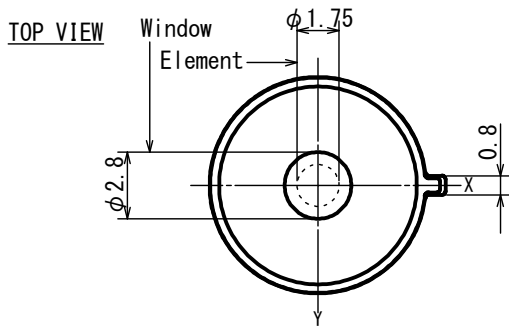

Tolerance with no specified : +/- 0.2

FOV

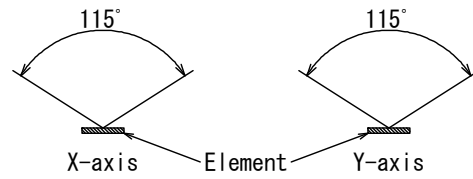

Circuit diagram

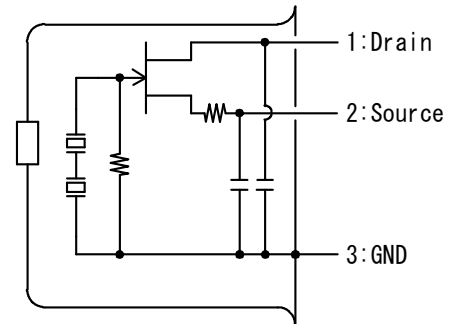

■ Main Parameter

Parameter	Condition	Spec.			Unit
		Min.	Typ.	Max.	
Operating Voltage		3		10	V
Source Voltage	Vd=5V, Rs=47kΩ, Ta=25°C	0.3		1.4	V
Sensitivity Output	72.5dB, 1Hz, 420K	1.5	2.7		V
Noise Output	72.5dB		60	200	mV
Operating Temperature		-40		70	°C

Analog

Amp build-in
ASIC build-in

SMD

Air-conditioner

Microwave
oven

Ih cooker

Printer

thermometer
Ear

Non-contact
thermometer

Pyroelectric IR sensor



SFM323-511

S-Pyro™

■ Applications Security

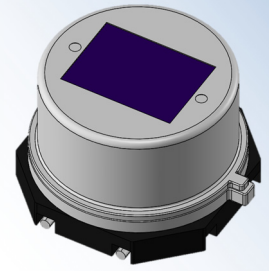

■ Feature Surface mount type
High EMC
High white light immunity

Dimensions

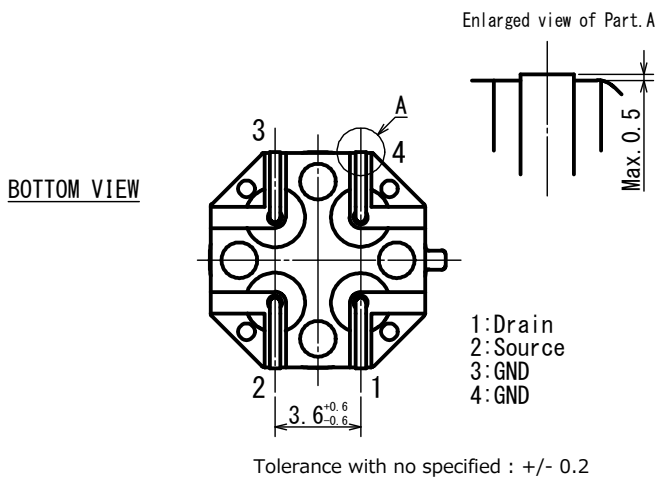
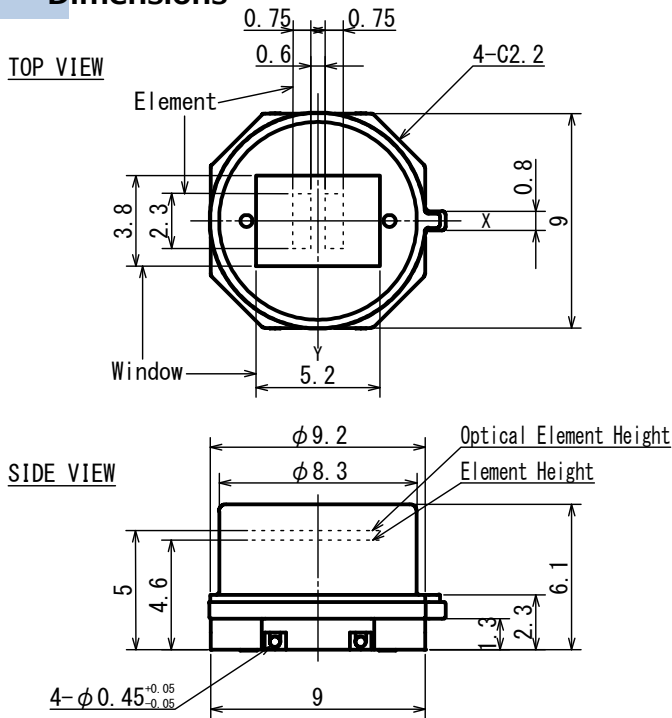

FOV

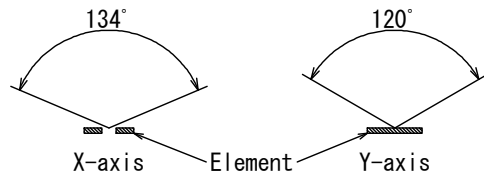

Circuit diagram

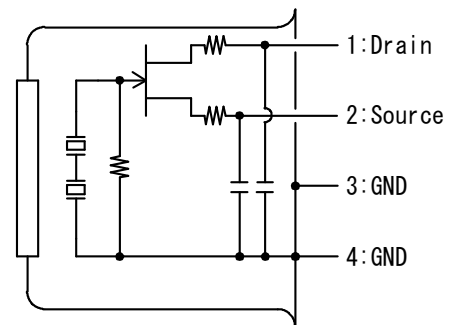

Recommendation Land Size

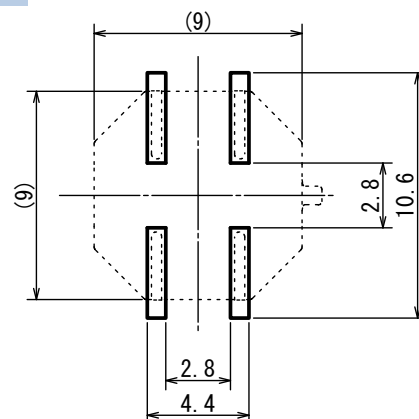

■ Main Parameter

Parameter	Condition	Spec.			Unit
		Min.	Typ.	Max.	
Operating Voltage		1		15	V
Source Voltage	Vd=5V, Rs=470kΩ, Ta=25°C	0.3		1.4	V
Sensitivity Output	72.5dB, 1Hz, 420K	2	3.5		V
Noise Output	72.5dB		70	250	mV
Operating Temperature		-40		70	°C

Analog

Amp build-in
ASIC build-in

SMD

Air-conditioner

Microwave
oven

Ih cooker

Printer

thermometer
Ear

Non-contact
thermometer

Pyroelectric IR sensor



SFM469-511

S-Pyro™
69-Pyro™

■ Applications Security

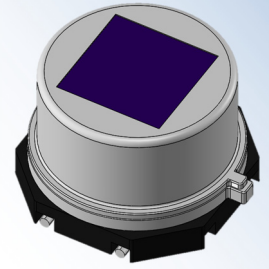

■ Feature Omni-directional dual sensor
(both ceiling mount and wall mount)
Surface mount type
High EMC

Dimensions

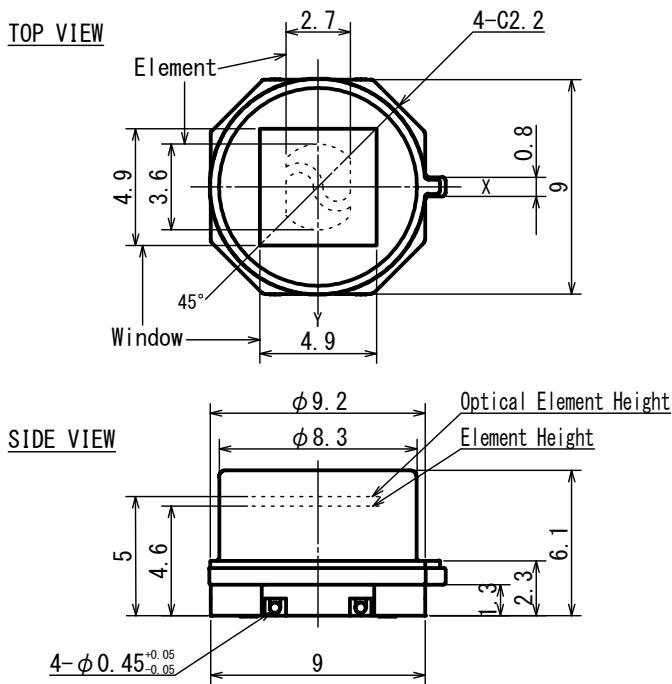

FOV

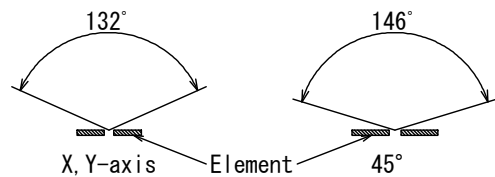

Circuit diagram

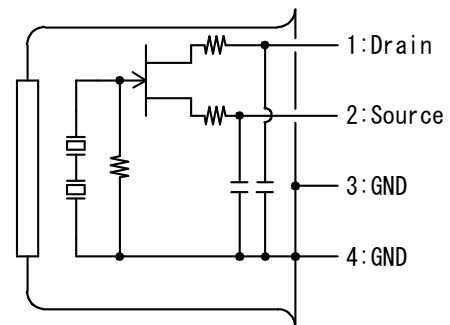

BOTTOM VIEW

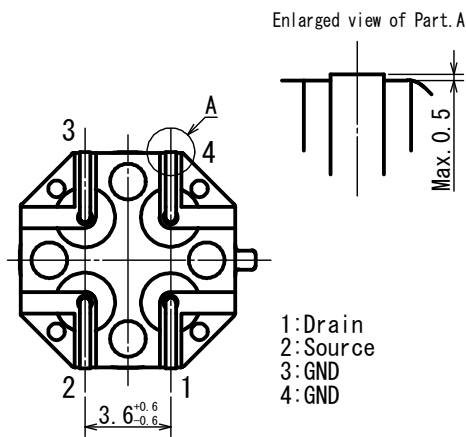

Tolerance with no specified : +/- 0.2

Recommendation Land Size

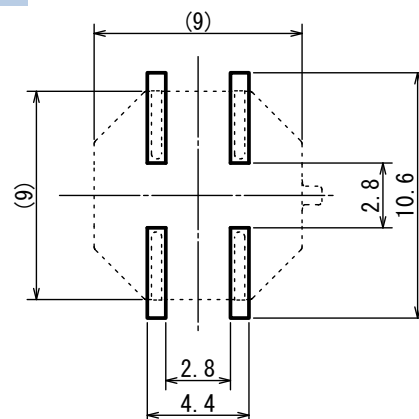

■ Main Parameter

Parameter	Condition	Spec.			Unit
		Min.	Typ.	Max.	
Operating Voltage		1		15	V
Source Voltage	Vd=5V, Rs=470kΩ, Ta=25°C	0.3		1.4	V
Sensitivity Output	72.5dB, 1Hz, 420K	2.2	3.6		V
Noise Output	72.5dB		70	250	mV
Operating Temperature		-40		70	°C

Pyroelectric IR sensor



SBM469-511

S-Pyro™
69-Pyro™

- Applications Lighting, Doorbell, IP Camera
HVAC, Home appliances

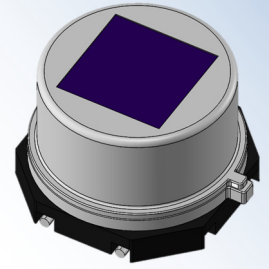

- Feature Omni-directional dual sensor
(both ceiling mount and wall mount)
Surface mount type

Dimensions

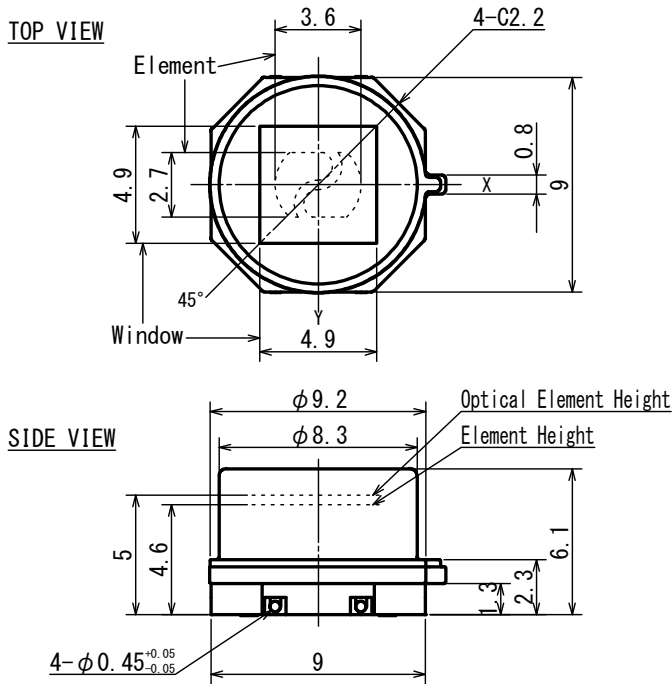

FOV

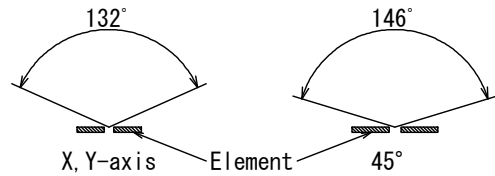

Circuit diagram

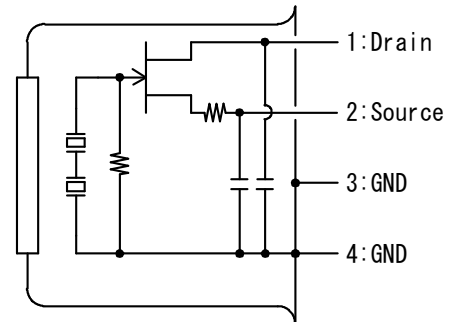

Recommendation Land Size

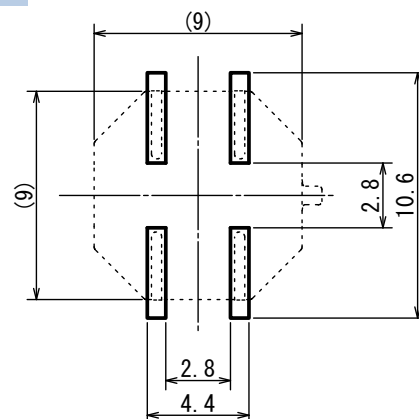

Main Parameter

Parameter	Condition	Spec.			Unit
		Min.	Typ.	Max.	
Operating Voltage		1		15	V
Source Voltage	Vd=5V, Rs=470k Ω , Ta=25°C	0.3		1.4	V
Sensitivity Output	72.5dB, 1Hz, 420K	2.2	3.6		V
Noise Output	72.5dB		70	250	mV
Operating Temperature		-40		70	°C

Analog

Amp build-in
ASIC build-in

SMD

Air-conditioner

Microwave
oven

IH cooker

Printer

thermometer
Ear

Non-contact
thermometer

Pyroelectric IR sensor



SLM323-511

S-Pyro™

- Applications Lighting, Doorbell, IP Camera
HVAC, Home appliances

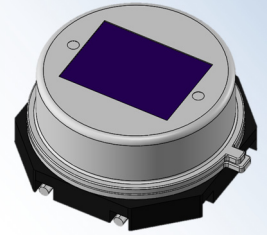

- Feature Low profile sensor
Surface mount type
High EMC

Dimensions

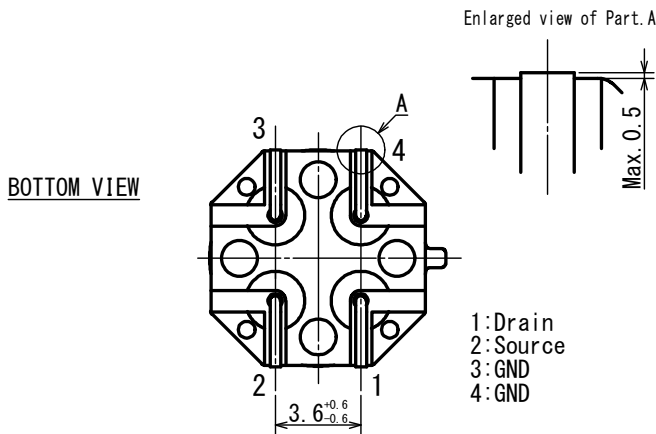
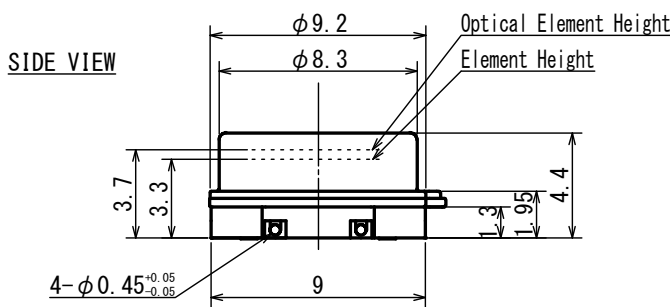
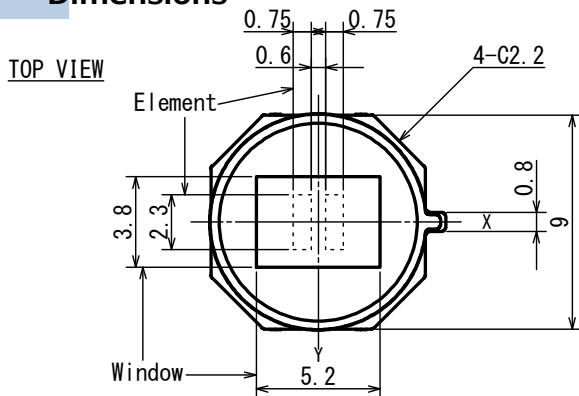

Tolerance with no specified : +/- 0.2

FOV

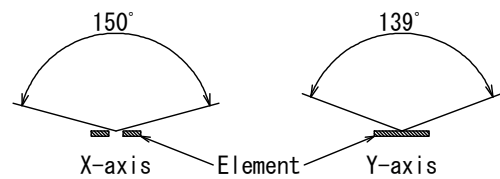

Circuit diagram

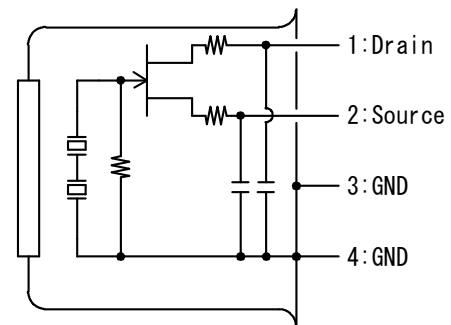

Recommendation Land Size

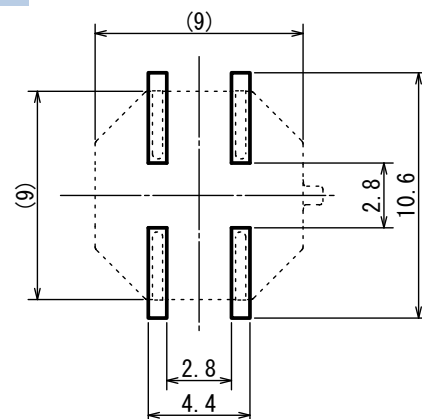

■ Main Parameter

Parameter	Condition	Spec.			Unit
		Min.	Typ.	Max.	
Operating Voltage		1		15	V
Source Voltage	Vd=5V, Rs=470kΩ, Ta=25°C	0.3		1.4	V
Sensitivity Output	72.5dB, 1Hz, 420K	2	3.5		V
Noise Output	72.5dB		70	250	mV
Operating Temperature		-40		70	°C

Pyroelectric IR sensor



SLM469-511

S-Pyro™
69-Pyro™

- Applications Lighting, Doorbell, IP Camera
HVAC, Home appliances

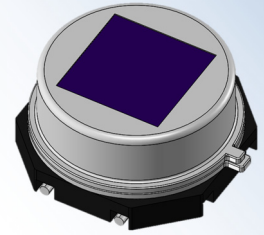

- Feature Low profile sensor
Omni-directional dual sensor
(both ceiling mount and wall mount)
Surface mount type

Dimensions

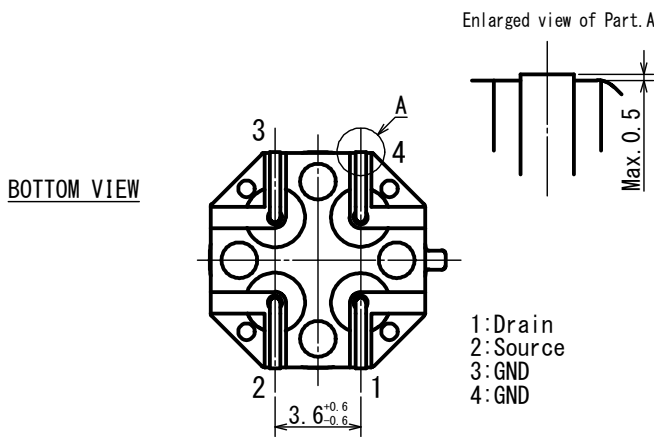
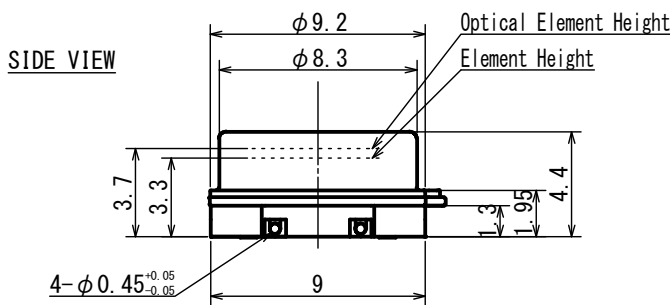
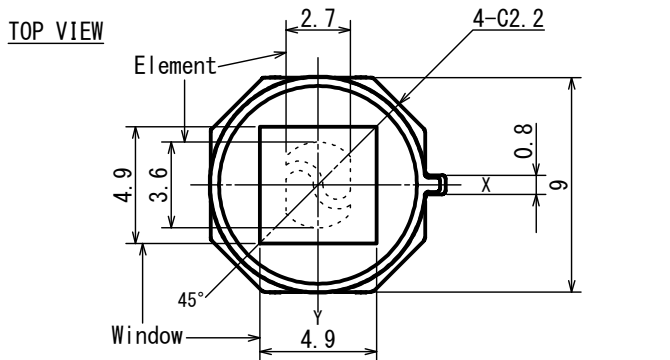

Tolerance with no specified : +/- 0.2

FOV

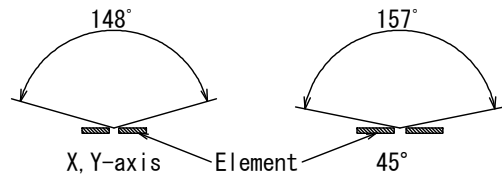

Circuit diagram

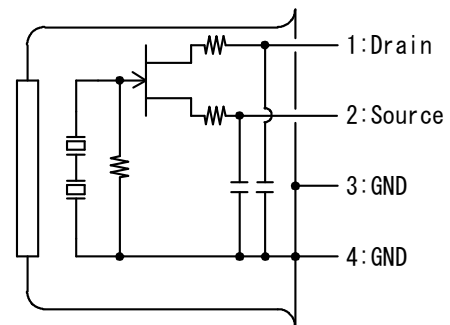

Recommendation Land Size

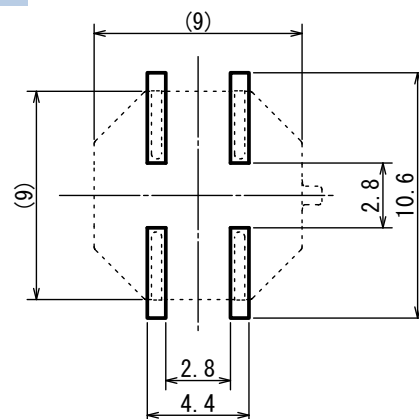

■ Main Parameter

Parameter	Condition	Spec.			Unit
		Min.	Typ.	Max.	
Operating Voltage		1		15	V
Source Voltage	Vd=5V, Rs=470kΩ, Ta=25°C	0.3		1.4	V
Sensitivity Output	72.5dB, 1Hz, 420K	2.2	3.6		V
Noise Output	72.5dB		70	250	mV
Operating Temperature		-40		70	°C

Analog

Amp build-in
ASIC build-in

SMD

Air-conditioner

Microwave
oven

IH cooker

Printer

thermometer
Ear

Non-contact
thermometer

Pyroelectric IR sensor



SUM469-20

S-Pyro™
69-Pyro™

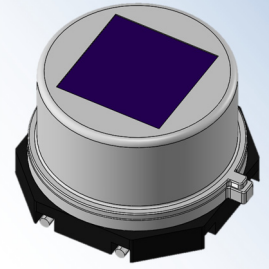

- Applications Doorbell, IP Camera
HVAC, Home appliances

- Feature Omni-directional dual sensor
(both ceiling mount and wall mount)
Surface mount type
Amp build-in type

Dimensions

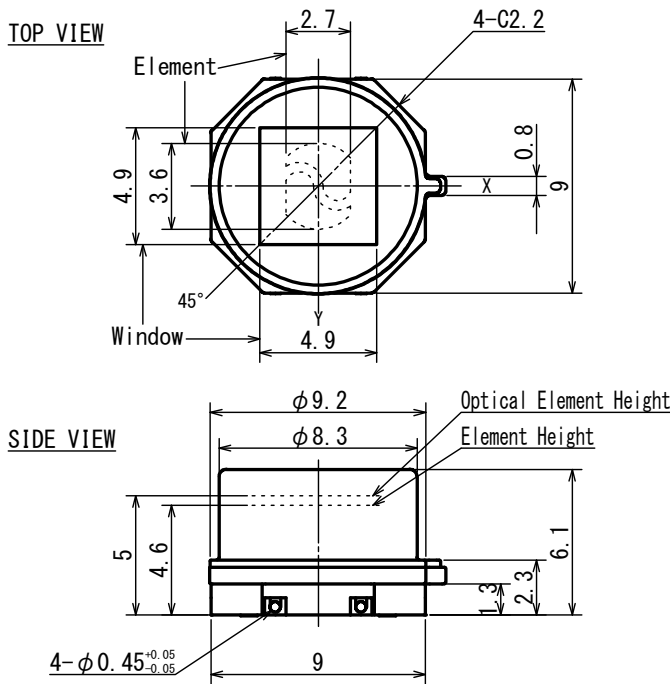

Tolerance with no specified : +/- 0.2

FOV

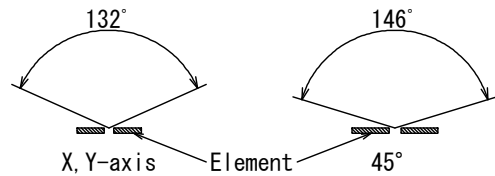

Circuit diagram

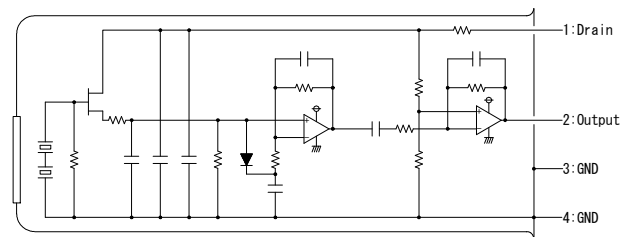

Recommendation Land Size

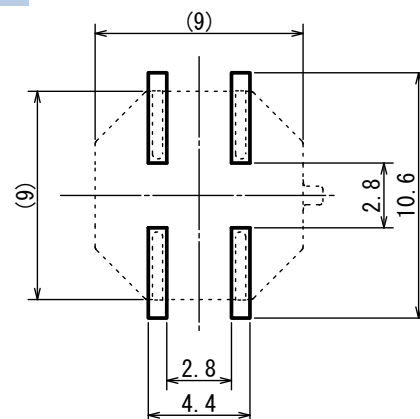

■ Main Parameter

Parameter	Condition	Spec.			Unit
		Min.	Typ.	Max.	
Operating Voltage		1.8		3.6	V
Offset Voltage			Vdd/2		V
Sensitivity Output		0.75	1.5		V
Noise Output			100	250	mV
Operating Temperature		-40		70	°C

1. Design restrictions/precautions

These sensors are designed for indoor use. If used for outdoor applications, please be sure to apply proper supplementary optical filter, drip-proof and anti-dew construction.

In cases where secondary accidents caused by operation failure or malfunction of the sensor could be expected, please include a fail safe function into the design.

2. Remarks

These sensors are not suitable for applications that require extremely high reliability, such as related to human life (life supporting devices and etc.).

These sensors must not be used for products that are prohibited to manufacture, use and sell by Japanese domestic and foreign laws and orders.

The contents described in this catalog are as of January 2021.

The described contents may be changed or suspended without notice.

Agent::Real Chance Co.,Ltd Taiwan:+886-2908-8287 China:+86-0769-82388628
<http://www.realchance.com.tw>

Nippon Ceramic Co., Ltd.

Technical Center

176-17, Hirooka,
Tottori-shi 689-1193 JAPAN
TEL +81-857-53-3600
(Pilot)
FAX +81-857-53-3676
Mail ip-sales@nicera.co.jp

<https://www.nicera.co.jp/>

Nicera European Works Ltd.

- NEW -
25 Copinger Close, Totton,
Southampton, Hants,
SO40 8WN United Kingdom
TEL +44-2380-667908
FAX +44-2380-663758

Nicera Hong Kong Ltd.

- NHK -
Unit L1, 5/F, Phase 2,
Kaiser Estate,
NOS 47-53 Man Yue Street,
Hung Hom, Kowloon,
Hong Kong, China
TEL +852-2795-7511
FAX +852-2754-3957

Nicera America Corp.

- NAC -
16461 Sherman Way,
Suite 248, Van Nuys,
CA 91406, USA
TEL +1-818-779-2100
FAX +1-818-779-2111